



## Inline filter

**RE 51402** 1/14  
 Edition: 2023-06  
 Replaced: 2021-04

**Types 100 FLEN 0160 to 0630; 100 FLE 0045, 0055, 0120**

Nominal sizes **according to DIN 24550**: 0160 to 0630  
 Nominal sizes according to Hengst standard: 0045,  
 0055, 0120  
 Nominal pressure 100 bar  
 Connections up to SAE 3"  
 Operating temperature -10 °C to +100 °C



H7590

### Table of contents

Contents	Page
Application, Features	1
Design, Filter element, Accessories, Characteristic curves, Quality and standardization	2
Ordering code	3
Preferred types	4
Ordering details:	
Electronic switching element for maintenance indicator	5
Plug-in connectors according to IEC 60947-5-2	5
Filter design	6
Symbols	7
Technical data	8
Unit dimensions	9
Spare parts list	10, 11
Directives and standardization	12
Installation, commissioning and maintenance	13

### Application

- Filtration of pressure fluids and lubricants.
- Filtration of fluids and gases.
- Direct installation into pipelines.
- Direct wear protection of downstream components and systems.
- Offline filtration at high filter service lives.

### Features

- Filters for inline installation
- Particularly suited for off-line filtration
- Extremely large filter area
- Flow-optimized design due to 3D computer-supported design
- Low pressure drop
- Special highly efficient filter media

## Design

---

Two-part design of filter housing with inlet and outlet as well as flange-mounted filter cover.

Further design variants available on request.

## Filter element

---

Pleated design with optimized pleat density and various filter media.

For further detailed information please refer to our brochure "Filter elements".

The filter element is the most important component of the "FILTER" system in view of prolonged life and the wear protection of the systems.

The most important criteria for selection are the required degree of cleanliness of the operating medium, the initial pressure differential and the contamination retention capacity.

## Accessories

---

### Maintenance indicator

Basically, the filter is equipped with mechanical optical maintenance indicator. The electronic maintenance indicator is connected via the electronic switching element with 1 or 2 switching points, which has to be ordered separately. The electronic switching element is attached to the mechanical optical maintenance indicator and held by means of a locking ring.

## Characteristic curves

---

An optimum filter selection is made possible by our "FilterSelect" software, see download area <http://www.filterselect.de/>.

Additional characteristic curves for the filters in this catalogue can be found in the FilterSelect filter calculation program.

## Quality and standardization

---

The development, manufacture and assembly of Hengst industrial filters and Hengst filter elements is carried out within the framework of a certified quality management system in accordance with ISO 9001:2015.

The pressure filters for hydraulic applications according to 51402 are pressure holding equipment according to article 1, section 2.1.4 of the pressure equipment directive 97/23/EC (DGRL). However, on the basis of the exception in article 1, section 3.6 of the DGRL, hydraulic filters are exempt from the DGRL if they are not classified higher than category I (guideline 1/19). They do not receive a CE mark.

## Ordering code

### Of the filter

<b>Pressure</b> 100 bar = 100	<b>Design</b> Inline filter with filter element according to DIN 24550 = FLEN Inline filter with filter element according to Hengst standard = FLE	<b>Nom. size</b> FLEN... = 0160 0250 0400 0630 FLE... = 0045 0055 0120	<b>Filtration rating in µm</b> <b>Nominal</b> Stainless steel wire mesh, cleanable: G10, G25 = G... Paper, non-cleanable P10 = P... <b>Absolute (ISO 16889)</b> Micro glass, non-cleanable: PWR3, PWR10, PWR20 = PWR..	<b>Pressure differential</b> Max. admissible pressure differential of the filter element 30 bar = A 160 bar = C	<b>Element model</b> Standard adhesive T = 100 °C = 0... Standard material = ...0 Chemically nickel-plated = ...D <sup>1)</sup>	<b>Solenoid</b> without = 0	<b>Complementary details</b> 0 = without Z <sup>2)</sup> = Certificate	<b>Material</b> 0 = Standard	<b>Seal</b> M = NBR-seal V = FKM-seal	<b>Connection</b> S0 = SAE flange	<b>Maintenance indicator</b> V5,0 = Maintenance indicator, optical State switching pressure 5.0 bar	<b>Bypass valve</b> 0 = without 9 = 7 bar
----------------------------------	--	--	---	--	--	--------------------------------	--	---------------------------------	---	--------------------------------------	---	---

**Ordering example:**  
100 FLE 0045 PWR10-A00-09V5,0-S0M00

### Of the filter element

<b>Filter element</b> Design = 1.	<b>Nom. size</b> FLEN... = 0160 0250 0400 0630 FLE... = 0045 0055 0120	<b>Filtration rating in µm</b> <b>Nominal</b> Stainless steel wire mesh, cleanable: G10, G25 = G... Paper, non-cleanable: P10 = P... <b>Absolute (ISO 16889)</b> Micro glass, non-cleanable: PWR3, PWR10, PWR20 = PWR..	<b>Pressure differential</b> Max. admissible pressure differential of the filter element 30 bar = A 160 bar = C	<b>Seal</b> M = NBR-seal V = FKM-seal	<b>Bypass valve</b> 0 = with filter element always 0	<b>Element model</b> 0... = Standard adhesive T = 100 °C ...0 = Standard material ...D <sup>1)</sup> = Chemically nickel-plated
--------------------------------------	--	--	--	---	---	--

**Ordering example:**  
1. 0045 PWR10-A00-0-M

<sup>1)</sup> Only in connection with FKM seal

<sup>2)</sup> Manufacturer's inspection certificate M according to DIN 55350 T18

## Preferred types

### Inline filter with bypass, filtration rating 10 µm and nominal pressure 100 bar

Type	Flow in L/min at $v = 30 \text{ mm}^2/\text{s}$ and $\Delta p = 0.8 \text{ bar}$	Material number
100 FLEN 0160 PWR10-A00-09V5,0-S0M00	317	R928000536
100 FLEN 0250 PWR10-A00-09V5,0-S0M00	416	R928000537
100 FLE 0045 PWR10-A00-09V5,0-S0M00	496	R928000540
100 FLE 0055 PWR10-A00-09V5,0-S0M00	537	R928000541
100 FLEN 0400 PWR10-A00-09V5,0-S0M00	885	R928000538
100 FLEN 0630 PWR10-A00-09V5,0-S0M00	1129	R928000539
100 FLE 0120 PWR10-A00-09V5,0-S0M00	1355	R928000542

### Inline filter with bypass, filtration rating 3 µm and nominal pressure 100 bar

Type	Flow in L/min at $v = 30 \text{ mm}^2/\text{s}$ and $\Delta p = 0.8 \text{ bar}$	Material number
100 FLEN 0160 PWR3-A00-09V5,0-S0M00	135	R928000529
100 FLEN 0250 PWR3-A00-09V5,0-S0M00	210	R928000530
100 FLE 0045 PWR3-A00-09V5,0-S0M00	310	R928000533
100 FLE 0055 PWR3-A00-09V5,0-S0M00	385	R928000534
100 FLEN 0400 PWR3-A00-09V5,0-S0M00	390	R928000531
100 FLEN 0630 PWR3-A00-09V5,0-S0M00	610	R928000532
100 FLE 0120 PWR3-A00-09V5,0-S0M00	960	R928000535

### Inline filter without bypass, filtration rating 10 µm and nominal pressure 100 bar

Type	Flow in L/min at $v = 30 \text{ mm}^2/\text{s}$ and $\Delta p = 0.8 \text{ bar}$	Material number
100 FLEN 0160 PWR10-C00-00V5,0-S0M00	317	R928000578
100 FLEN 0250 PWR10-C00-00V5,0-S0M00	416	R928000579
100 FLE 0045 PWR10-C00-00V5,0-S0M00	496	R928000582
100 FLE 0055 PWR10-C00-00V5,0-S0M00	537	R928000583
100 FLEN 0400 PWR10-C00-00V5,0-S0M00	885	R928000580
100 FLEN 0630 PWR10-C00-00V5,0-S0M00	1129	R928000581
100 FLE 0120 PWR10-C00-00V5,0-S0M00	1355	R928000584

### Inline filter without bypass, filtration rating 3 µm and nominal pressure 100 bar

Type	Flow in L/min at $v = 30 \text{ mm}^2/\text{s}$ and $\Delta p = 0.8 \text{ bar}$	Material number
100 FLEN 0160 PWR3-C00-00V5,0-S0M00	135	R928000571
100 FLEN 0250 PWR3-C00-00V5,0-S0M00	210	R928000572
100 FLE 0045 PWR3-C00-00V5,0-S0M00	310	R928000575
100 FLE 0055 PWR3-C00-00V5,0-S0M00	385	R928000576
100 FLEN 0400 PWR3-C00-00V5,0-S0M00	390	R928000573
100 FLEN 0630 PWR3-C00-00V5,0-S0M00	610	R928000574
100 FLE 0120 PWR3-C00-00V5,0-S0M00	960	R928000577

## Ordering details: Electronic switching element for maintenance indicator

01	02	03
WE	-	-

### Maintenance indicator

01	Electronic switching element	WE
----	------------------------------	----

### Type of signal

02	1 switching point	1SP
	2 switching points, 3 LED	2SP
	2 switching points, 3 LED and signal suppression up to 30 °C [86 °F]	2SPSU

### Connector

03	Round plug-in connection M12x1, 4-pole	M12x1
	Rectangular connector, 2-pole, design A according to EN-175301-803	EN175301-803

### Material numbers of the electronic switching elements

Material no.	Type	Signal	Switching points	Connector	LED
R928028409	WE-1SP-M12x1	Changeover	1	M12x1	Without
R928028410	WE-2SP-M12x1	Normally open (at 75%) / normally closed contact (at 100%)	2		3 pieces
R928028411	WE-2SPSU-M12x1				
R928036318	WE-1SP-EN175301-803	Normally closed contact	1	EN 175301-803	Without

## Mating connector (max. permissible voltage: 50 V)

for electronic switching element with round plug-in connection M12x1

Mating connector suitable for K24 4-pole, M12x1 with screw connection, cable gland Pg9.

Material no. R900031155

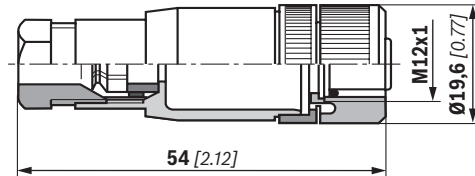

Mating connector suitable for K24-3m 4-pole, M12x1 with potted-in PVC cable, 3 m long.

Line cross-section: 4 x 0.34 mm<sup>2</sup>

Core marking: 1 brown 2 white  
 3 blue 4 black

Material no. R900064381

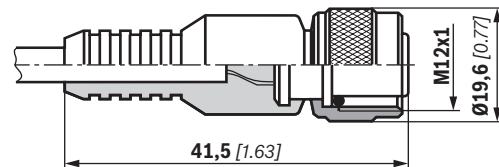

### Order example:

Pressure filter with mechanical optical maintenance indicator for  $p_{nom.} = 100 \text{ bar}$  [1450 psi] with bypass valve, nominal size 0045, with filter element 10 µm and electronic switching element M12x1 with 1 switching point for pressure fluid mineral oil HLP according to DIN 51524.

Filter: 100 FLE 0045 PWR10-A00-09V5,0-S0M00

Material number: R928000540

Maintenance indicator: WE-1SP-M12x1

Material number: R928028409

## Filter design

Easy selection of the filter size is made possible by the FilterSelect online tool. The filter can be designed using the operating pressure, flow and fluid system parameters. The required filter rating is based on the application, the sensitivity to contamination of the components and the environmental conditions.





The program leads you through the menu on a step-by-step basis.

A documentation of the filter selection can finally be created in the form of a PDF file. This file contains the entered parameters, the designed filter with material number including spare parts, and the pressure loss curves.

Link FilterSelect:  
<http://www.filterselect.de>

Other languages can be selected using the page navigation.

### standard search

application:	<input type="text" value="hydraulics for industrial use and applications with lubricating oil"/>
Product category:	<input type="text" value="please select"/>
type:	<input type="text" value="please select"/>
pressure range:	<input type="text" value="please select"/>
filter material:	<input type="text" value="please select"/> 
fineness:	<input type="text" value="please select"/>
volume flow rate:	<input type="text" value=""/> [l/min]
viscosity: * = working point	<input checked="" type="radio"/> kin viscosity 1: <input type="text" value="32"/> [mm <sup>2</sup> /s] 
	<input type="radio"/> search via type of medium <span style="float: right;">full-text search medium</span>
	<input type="text" value="please select"/> <input type="text" value=""/>
	<input type="text" value="please select"/> <input type="text" value=""/>
	temp 1: <input type="text" value=""/> [°C] <input type="text" value=""/> [°F] kin viscosity 1: <input type="text" value=""/> [mm <sup>2</sup> /s] 
	<input type="radio"/> dyn. Viscosity 1: <input type="text" value=""/> [cP] density 1: <input type="text" value=""/> [kg/dm <sup>3</sup> ] kin viscosity 1: <input type="text" value=""/> [mm <sup>2</sup> /s] 
collapse pressure resistance according to ISO 2941:	<input type="text" value="30 bar"/>
	<input type="button" value="Start search"/> 

## Symbols

Pressure filter

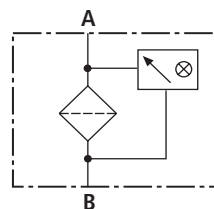
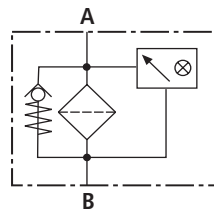

Electronic switching element  
for maintenance indicator

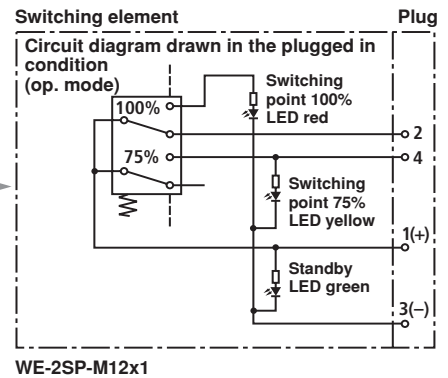
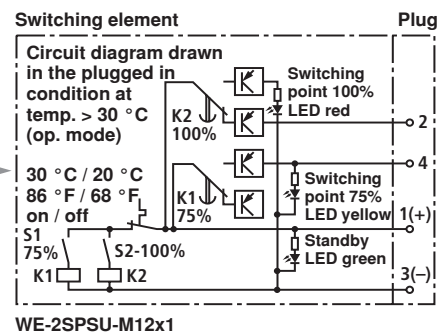
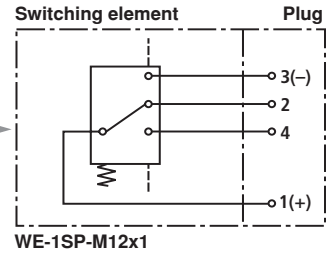

## Technical data (For applications outside these parameters, please consult us!)

### Electronic (electric switching element)

Electrical connection		Round plug-in connection M12 x 1, 4-pin
Contact load, direct voltage	A	Max. 1
Voltage range	E1SP-M12x1 V DC/AC	Max. 150
	E2SP V DC	10 to 30
Max. switching capacity with ohmic loads		20 VA; 20 W; (70 VA)
Switching type	E1SP-M12x1	Changeover
	E2SP-M12x1	Normally open at 75% of the response pressure, Normally closed at 100% of the response pressure
	E2SPSU-M12x1	Normally open at 75% of the response pressure, Normally closed at 100% of the response pressure Signal switching through at 30 °C [86 °F], Return switching at 20 °C [68 °F]
Display via LEDs in the electronic switching element E2SP...		Stand-by (LED green); 75% switching point (LED yellow) 100% switching point (LED red)
Type of protection according to EN 60529		IP 65
For direct voltage above 24 V a spark suppression is to be provided to protect the switching contacts.		
Weight	Electronic switching element: – with round plug-in connection M12 x 1 kg [lbs]	0.1 [0.22]

## Unit dimensions (dimensions in mm)

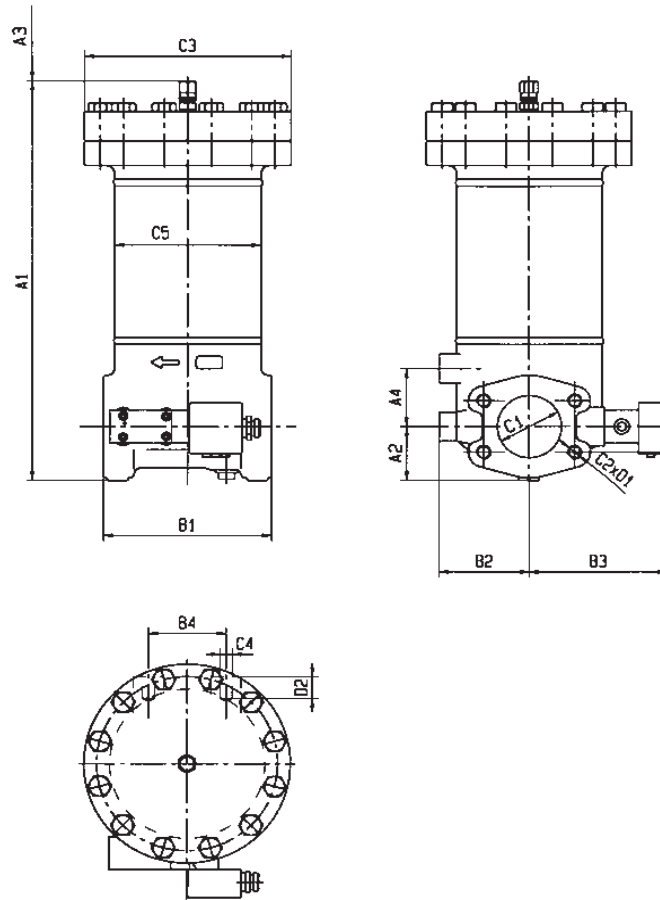

### Filter housing for filter elements in accordance with DIN 24550

Type 100 FLEN...	Volume in l	Weight in kg <sup>1)</sup>	A1	A2	A3 <sup>2)</sup>	A4	B1	B2	B3	B4	C1	C2	C3	C4	C5	D1	D2
0160	2.1	22.4	351	50	160	60	160	95	144	70	SAE 2" 3000 psi DN50	M12	Ø 200	M16	Ø 140	21	22
0250	3.2	28.0	441		250	70	195	105	158	90	SAE 3" 3000 psi DN80	M16	Ø 240	M16	Ø 170	22	20
0400	5.1	34.0	482	65	400	70	195	105	158	90	SAE 3" 3000 psi DN80	M16	Ø 240	M16	Ø 170	22	20
0630	7.8	38.3	632			70	195	105	158	90	SAE 3" 3000 psi DN80	M16	Ø 240	M16	Ø 170	22	20

### Filter housing for filter elements according to Hengst standard

Type 100 FLE...	Volume in l	Weight in kg <sup>1)</sup>	A1	A2	A3 <sup>2)</sup>	A4	B1	B2	B3	B4	C1	C2	C3	C4	C5	D1	D2
0045	5.1	29.0	591	50	400	60	160	95	144	70	SAE 2" 3000 psi DN50	M12	Ø 200	M16	Ø 140	21	22
0055	7.1	33	759		568	70	195	105	158	90	SAE 3" 3000 psi DN80	M16	Ø 240	M16	Ø 170	22	20
0120	14.3	49.2	989	65	750	70	195	105	158	90	SAE 3" 3000 psi DN80	M16	Ø 240	M16	Ø 170	22	20

<sup>1)</sup> Weight including standard filter element and maintenance indicator. <sup>2)</sup> Withdrawal dimension for filter element replacement.

## Spare parts list

100 FLEN 0160 - 0630  
 100 FLE 0045 - 0120

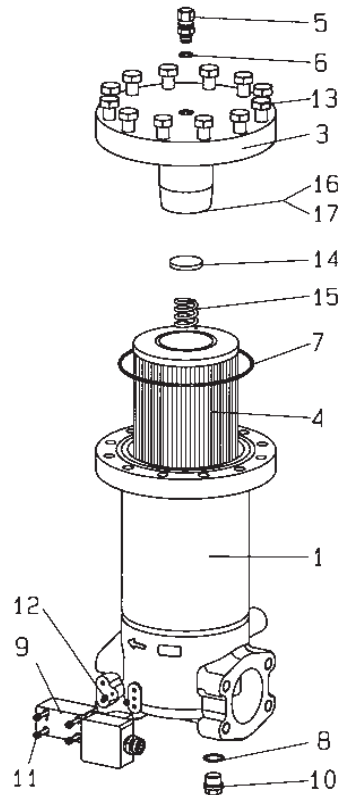

Part	Piece	Description	Material	Size						
				FLEN	0160	0250	0045	0055	0400	0630
1	1	Filter housing	Various	Please indicate ordering information "Filter"						
3	1	Filter cover	Various	Please indicate ordering information "Filter"						
4	1	Filter element	Various	Please indicate ordering information "Filter Element"						
5	1	Bleed screw	5.8	Part No. 4158						
6	1	Seal ring	Soft steel	Please indicate ordering information "Filter"						
7	1	Seal ring	NBR / FKM	Please indicate ordering information "Filter"						
8	1	Seal ring	Soft steel	Please indicate ordering information "Filter"						
9	1	Maintenance indicator	Various	See ordering information "Maintenance indicator"						
10	1	Plug	Steel	Part No. 789						
11	4	Hexagon socket head cap screw	8.8	Part No. 633						
12	2	Seal ring	NBR / FKM	Please indicate ordering information "Filter"						
13	8	Hexagonal head screw	8.8	Part No. 602			-			
	12			-			Part No. 603			
14	1	Valve calotte	Various	Please indicate ordering information "Filter"						
15	1	Valve spring	1.0600							
16	1	Valve disk	Steel							
17	1	Locking ring	Spring steel							

All part no.s Hengst specific.

## Ordering code Spare parts

### Mechanical/optical maintenance indicator

01	02	03	04	05	06
W	O	-	D01	-	-

01	Maintenance indicator	W
----	-----------------------	---

02	mechanical/optical indicator	O
----	------------------------------	---

### Version

03	Design pressure differential M20x1.5	D01
----	--------------------------------------	-----

### Switching pressure

04	2.2 bar [32 psi]	2,2
	5.0 bar [72.5 psi]	5,0
	8.0 bar [116 psi]	8,0

### Seal

05	NBR seal	M
	FKM seal	V

### Max. operating pressure

06	Switching pressure 2.2 bar [31.9 psi], 160 bar [2321 psi]	160
	Switching pressure 5.0 bar [72.5 psi], 450 bar [6527 psi]	450
	Switching pressure 8.0 bar [116 psi], 450 bar [6527 psi]	450

### Mechanical/optical maintenance indicator

Material no.	Mechanical/optical maintenance indicator
R901025312	WO-D01-2,2-M-160
R901025313	WO-D01-5,0-M-450
R901066233	WO-D01-2,2-V-160
R901066235	WO-D01-5,0-V-450
R928038785	WO-D01-8,0-M-450
R928038784	WO-D01-8,0-V-450

The ordering details for filter elements and sealing kits can be found on page 3.

**Sealing kits must be ordered by stating the complete part key.**

### Sealing material and surface coating for pressure fluids

			Order detail	
Mineral oils			Sealing material	Element model
Mineral oil	HLP	according to DIN 51524	M	...0
Fire-resistant hydraulic fluids				
Emulsions	HFA-E	according to DIN 24320	M	...0
Synthetic water solutions	HFA-S	according to DIN 24320	M	...D
Water solutions	HFC	according to VDMA 24317	M	...D
Phosphate esters	HFD-R	according to VDMA 24317	V	...D
Organic esters	HFD-U	according to VDMA 24317	V	...D
Hydraulic fluids that are fast biodegradable				
Triglycerides (rape seed oil)	HETG	according to VDMA 24568	M	...D
Synthetic esters	HEES	according to VDMA 24568	V	...D
Polyglycoles	HEPG	according to VDMA 24568	V	...D

## Directives and standardization

---

### Product validation

Hengst filters, the filter elements built into them and filter accessories are tested and quality-monitored according to different ISO test standards:

Pressure pulse test	ISO 10771:2015-08
Filtration performance test (multipass test)	ISO 16889:2008-06
$\Delta p$ (pressure loss) characteristic curves	ISO 3968:2001-12
Compatibility with hydraulic fluid	ISO 2943:1998-11
Collapse pressure test	ISO 2941:2009-04

The development, manufacture and assembly of Hengst industrial filters and Hengst filter elements is carried out within the framework of a certified quality management system in accordance with ISO 9001:2015.

## Installation, commissioning and maintenance

### Installation

Verify operating pressure with name plate information.

Screw the filter housing Pos. 1 to the fastening device, considering the flow direction (direction arrows) and the withdrawal height of the filter element Pos. 4.

Remove the plugs from the filter inlet and outlets. Fit the filter into the pipe work, ensuring that it is fitted free of tension.

#### **Warning!**

Assemble and disassemble the filter only when system is depressurized!

Vessel is under pressure!

When disassembling the filter, please note that the filter inlet and the filter outlet need to be emptied separately!

Remove the filter bowl only if it is not pressurized!

Do not replace the maintenance indicator while the filter is under pressure!

Functional and safety warranty only applicable when using genuine Hengst spare parts!

Service filter only by trained personnel!

### Commissioning

Switch on system pump.

Bleed filter by opening the plug / bleed valve position 5, close when operating fluid vents.

### Maintenance

If at operating temperature, the red indicator pin shows out of the maintenance indicator Pos. 9 and/or if the switching process in the electric display is triggered, the filter element is clogged and needs to be replaced or cleaned.

### Filter element replacement

Switch of the system pump.

Open bleed screw (position 5) and relieve pressure.

Open plug Pos. 10 and drain the contaminated oil from the filter housing.

Unscrew the filter head / filter cover Pos. 3 and remove the filter element from the centering spigot in the lower filter part by turnign it lightly and remove it from the filter housing.

Again close plug Pos. 10.

Replace filter elements PWR.. and P..., clean the filter element with material G .... The efficiency of the cleaning process depends on the type of contamination and the value of the pressure differential before the filter element was exchanged.

If the pressure differential after replacing the filter element is more than 50% of the value before replacing the filter element then the G.... element also needs to be replaced.

Install the cleaned or new filter element into the filter housing and with light turning movements push it on to the centering spigot. Beforehand, apply some oil to the seal ring in the filter element. During installation take care to ensure that the filter element is not damaged due to contact on the top edge of the mantel tube.

Check the seal ring Pos. 7 in the mantel tube for damage or wear and replace if necessary.

Re-mount the filter cover with hexagonal head screws. (100 FLE...).

Carry out commissioning as described above.

Technical modifications reserved!